

## **A Study of Gesture-based Electronic Musical Instruments**

prepared for Penny Beebe  
*Engineering Communications Program*

Bruce Land  
*School of Electrical and Computer Engineering*  
*Department of Neurobiology and Behavior*

David Borden  
*Department of Music*

by Paul Grzymkowski  
*School of Electrical and Computer Engineering*

Cornell University  
December 13, 2001

## I. INTRODUCTION

Gesture-based electronic musical instruments allow performers to express themselves musically, while operating outside the confines of conventional electronic instruments. Musical controllers, in general, are devices that convert human movement into digital signals (data represented by a discrete set of voltages), which are ultimately converted into music by a computer. Unlike typical controllers, such as keyboard synthesizers, which consist of an array of keys that correspond to specific musical notes when pressed, controllers based on gestures use computers to interpret motion from a wide variety of sensory devices, which can be converted into diverse aspects of the music. The position of a hand in space, for example, can be used to control the timbre of a sound (the qualities that distinguish it from other sounds), or the tempo of the piece.

The purpose of my research was to explore the various light, motion, and pressure sensing devices used in current gesture-related electronic instruments, and to investigate how the computer uses the information to generate music.

## II. SOURCES

I have primarily used journal articles and conference proceedings for my research, but I have also found pertinent information in an unpublished Master's thesis, product manuals, and a personal interview. The IEEE Xplore and INSPEC databases have provided online access to a sufficient number of conference proceedings that discuss gestural music control, such as *Electronic Music: New Ways to Play*, by Joseph Paradiso and *Devices for Interactive Computer Music and Computer Graphics Performances*, by Tarabella, Magrini, and Scapellato . In addition, the *Journal of New Music Research* and the *Computer Music Journal*, have provided many articles with excellent perspectives on the topic. I have spoken with Professor David Borden, the director of the Digital Music Program in the Department of Music at Cornell University, who has given me information about his experiences with the Expressive Footwear project of the Massachusetts Institute of Technology's (MIT) Media Lab.

### III. DISCUSSION

#### A. Background Information

##### 1. Music through Gesture

A gesture is a movement of the hands or body used to express an idea. To better convey the thoughts or emotions we cannot vocalize, we often choose to use gestures. Similarly, musical instruments allow us to convert our thoughts and feelings into audible sound through “bowing, blowing, banging, plucking, pushing, pulling, rubbing, and strumming” (Goldstein, 1998, p. 1076). The heavy pressing of piano keys may represent anger, while the gentle plucking of a guitar string may represent happiness. Gesture-based electronic instruments, however, do not have keys or strings at all, because pressing a key “might not be sufficient to capture the deepest expressive content”(Camurri, 1999, p. 356) of the performer. The “preparation before the gesture” and the motions after the gesture could also be relevant, and need to be recorded (Camurri, 1999, p. 356). Therefore, these types of instruments rely on more abstract inputs such as a waving of the hands, stamping of the feet, or position of the body in space, to manipulate the music. They give musicians many additional degrees of expression, but they require a well-defined interface to ensure there is “immediacy between an action and the resulting sound” (Goldstein, 1998, p. 1076). In most modern gesture-based instruments, the interface takes one of three forms, those based on contact control (wearing or manipulating devices designed to sense body movements), body obstruction (using the body to obstruct specific areas monitored by external sensors), or body transmission (using the body as a transmitter to devices that take advantage of the body’s physical properties).

##### 2. MIDI Protocol

Since electronic instruments do not inherently produce acoustic sound, a computer is needed to convert the information collected from the sensory devices into music. By “[i]nterposing a computer in the loop between physical action and musical response” an unlimited variety of mappings (connections between an action and a resulting sound) can be defined (Paradiso, 1999a). The Musical Instrument Digital Interface (MIDI), a music

description language for the computer, is used to trigger notes while manipulating their tempo, velocity (the speed of the attack), pitch, and other characteristics as determined by these mappings. A musician can use the MIDI protocol to trigger whatever software synthesizers (computer applications that produce music), sound effects, or sequences of notes they desire (Hass, 1998). Each gesture-based instrument varies in its MIDI configuration.

## B. Contact Control

### 1. Lady's Glove

Possibly the most straightforward method of converting human movement into music is to record movement via sensors that come directly in contact with the body. One particular device, Laetitia Sonami's Lady's Glove, is worn on the hand. It has bend sensors which "measure the inclination of both finger joints [in] the middle three fingers" (Paradiso, 1997, p. 30) and touch sensors at the fingertips to detect pressing against the thumb, or interactions with other objects. Sensors utilizing the Hall effect can measure the distance to each finger from a magnet in the thumb. These Hall effect sensors "respond with an output voltage to a variation of [an] applied magnetic field", and they are "sensitive to the direction and magnitude" of that field (Ferrazzin et al., 1999, p. 220). In a simple sensor, a current is applied to a small piece of conductive material (in which current can flow easily). If the sensor is placed near a magnet (such as in the thumb of the Lady's Glove), a magnetic field will be generated, and the resulting voltage of the sensor can be expressed as

$$V_h = (R_h \times I_c \times B) / t_c \quad (1)$$

where  $V_h$  is the output in Volts,  $R_h$  is the Hall coefficient in  $\text{cm}^3/\text{Coulomb}$  (where 1 Coulomb = 1 Ampere x 1 second),  $I_c$  is the current flowing through the conductor in Amperes,  $B$  is the field generated by the magnet in Gauss (1 Gauss = .0001 Tesla = .0001  $\text{Vs/m}^2 = \text{Vs/cm}^2$ ), and  $t_c$  is the thickness of the conductor in cm. We can see from this relationship that the voltage produced by the sensor is directly proportional to the magnetic field. Therefore, as the thumb of the Lady's Glove is brought closer to the fingers, the intensity of the magnetic field on each of the finger sensors increases, and the

change in voltage can be recorded. The Lady's Glove also uses "sonar ranging [(receivers that use waves to detect the distance of an object)] to emitters in the belt and shoe" (Paradiso, 1999a) which relay information about the location and orientation of the glove to a computer. The data from each of the sensors is interpreted by the computer and assigned to various aspects of the music. With a wave of the hand, the pitch and intensity of a sound can be manipulated.

## 2. Digital Baton

Another device that requires contact for its functionality is the Digital Baton developed at the Media Lab of the Massachusetts Institute of Technology (MIT). The baton, similar in size and design to a conductor's wand, has three sensory devices: a three-axis array of 5g accelerometers, an infrared (IR) light-emitting diode (LED) at its tip, and five force sensors in the base to "measure continuous pressure of the thumb, index finger, middle finger, combined last two fingers, and palm" (Paradiso, 1999b, p. 141). A block diagram of the baton, separated into its key components and functions, can be found in Appendix A. The analog accelerometers convert the movement of a small proof mass (object of known weight) into a continuous voltage signal. Based on Newton's first law that "an object at rest stays at rest", the mass will have a tendency to initially stay at rest when the other part of device is suddenly moved. The result is a small displacement between an electrode (a collector and emitter of charge) on the mass and an electrode on the casing of the device, which is measured as a capacitance (storage of charge). With three of these accelerometers, one for each direction in space (represented by a cube in Appendix A), a complete description of the baton's movements can be generated. A microprocessor (a small, specialized computer chip) in the base of the baton is used to convert the analog signals from the accelerometers and finger pressure sensors into an 8-bit digital signal transmitted one bit at a time over a serial cable (shown in Appendix A), connected to a computer nearby. (Paradiso, 1999b, p.142)

The position of the Digital Baton in space is measured via the LED on the tip in conjunction with a two-dimensional position-sensitive photodiode (PSD) camera. The

PSD camera is placed a few meters away from the stage and is calibrated to sense only

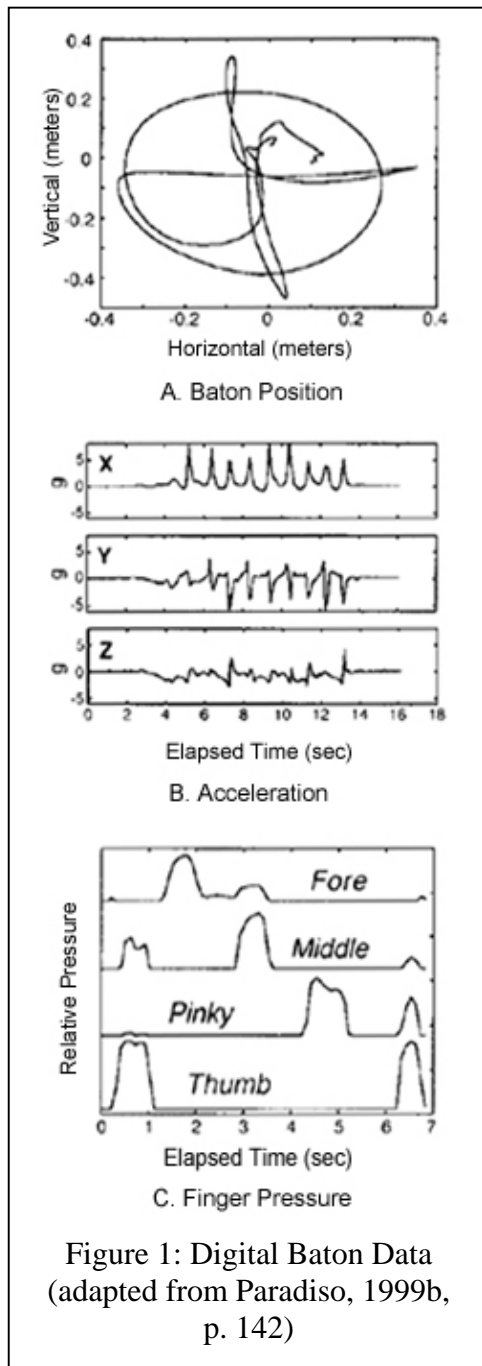

Figure 1: Digital Baton Data (adapted from Paradiso, 1999b, p. 142)

the IR light coming from the LED, which is modulated at 20 kHz. This process ensures that the “unpredictable background from incandescent stage lighting” (Paradiso and Sparacino, 1997) does not interfere with the position detection of the device. The camera is capable of directly outputting horizontal and vertical information about the baton, without any computer image processing necessary. (Paradiso, 1999b, p. 142) Sample data from the baton is shown in Figure 1. The baton’s horizontal and vertical position is shown in Figure 1a, three-axis acceleration is shown in Figure 1b, and four of the finger pressures are shown in Figure 1c. The data from each of the sensors can be used to control a different aspect of the music. The sharp peaks of the acceleration, known as beats, are used to control percussive elements, and accents of the piece. Finger pressure is often used to alter the speed of the sequence, or to change between control modes. The position information of the baton has many uses, for instance, it can be used to manipulate a digital guitar sound; “the vertical tip position controls . . . pitch and the horizontal position controls timbre” (Paradiso, 1997). In

addition, the baton has a visible LED on its tip, which is used to cue the musician throughout the performance.

The Digital Baton has been used hundreds of times in MIT’s multimedia show, the *Brain Opera*. The musical pieces "Lorraine Melody" and "Theme Song" were specifically

composed for the baton by Tod Machover, Professor of Music and Media at MIT. “Lorraine Melody” has “eight separate tracks of music, five of which are under the direct control of the [performer]” (Marrin, 1996). The first four tracks contain preset sequences that can be selected by the baton, by positioning it from left to right in one of four designated spaces, then pressing down one of two sensors. If it is held down, the volume of the track can be modified by moving the baton up and down in space. The fifth track has an ever-changing assortment of samples that can be selected (by pointing and pressing as before) and mixed into the piece. (Marrin, 1996)

In “Theme Song” all four tracks of music can be controlled by the performer. In this scenario, the two-dimensional space is divided into six regions, each with its own group of instrument sounds to select and manipulate. These sounds include the “piano, organ, mallet percussion, guitar, flute, and trumpet” (Marrin, 1996). The user can change the volumes of these sounds by adjusting thumb pressure, and can add accents to the piece, whose intensities are “velocity-sensitive” (Marrin, 1996).

### 3. SICIB

While some electronic instruments are limited to inputs based on finger motions, Sistema Interactivo de Composición e Improvisación para Bailarines (SICIB) is “capable of generating music in real time based on body motion” (Morales-Manzanares et al., 2001, p. 26). SICIB, the Interactive System of Composition and Improvisation for Dancers (in English), obtains its sensory information through the Flock of Birds (Flock) system developed by Ascension Technology Corporation. Flock (depicted in Figure 2) enables SICIB to generate “up to 144 position and orientation measurements per second within a 10-foot radius” (Morales-

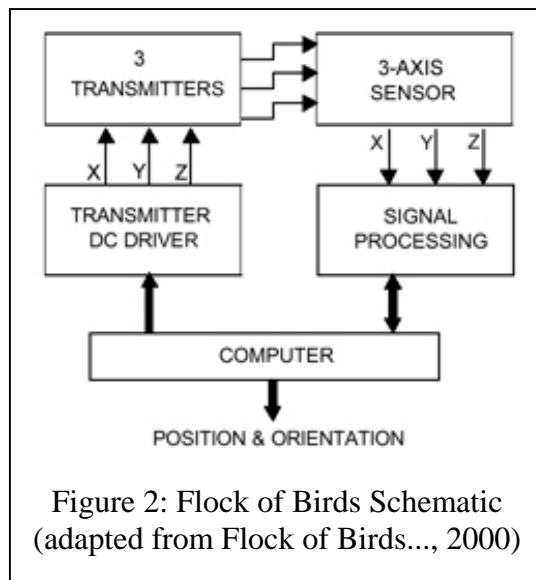

Manzanares et al., 2001, p. 27). Flock consists of three transmitting antennas (X, Y, and Z) driven by a circuit board, a three-axis receiver (X, Y, and Z), and signal processing circuitry. As the three transmitters are driven one at a time with a direct current (DC) source, the sensory information of the corresponding axis of the receiver is read and processed. A computer is used to ensure that the transmitters and receivers are properly synchronized. As a receiver moves closer to the appropriate transmitter, the signal generated will increase in amplitude. The computer then interprets these amplitudes as a function of time and can convert the data into three-dimensional position and orientation coordinates. Additional calibration considerations also need to be made to eliminate the effect of the Earth's magnetic field. (Flock of Birds..., 2000)

With SICIB, the performers wear a number of Flock receivers on their body, which are used to measure various choreographic components, including “(1) curvature and torsion of movements, (2) physical position of the dancer, (3) displacement velocity and acceleration, and (4) sudden changes” (Morales-Manzanares et al., 2001, p. 28). These characteristics can all be calculated from the generated position and orientation coordinates through fairly standard calculations on the computer, and interpreted with two pieces of MIDI software: Escamol and Aura. Escamol uses algorithms to generate music “in real time following compositional grammar rules” (style of the composer) by mapping the data onto volume, tone, instrument type, tempo, and other qualities of the music, while Aura uses the data to control software synthesizers (Morales-Manzanares et al., 2001, pp. 29-30). In typical performances using SICIB, dancers wear two sensors, one on each hand. Up to four sensors have been used; however, using more causes problems as “the dancer can be overloaded with information, making it difficult to follow the musical implications of physical gesture” (Morales-Manzanares et al., 2001, p. 34).

#### 4. Expressive Footwear

Instead of holding an electronic instrument, with Expressive Footwear (another instrument out of MIT's Media Lab) the performer can actually wear it. These wireless, 9V battery-operated shoes can obtain a wealth of sensory information (sixteen separate



parameters), while still providing a great amount of freedom to the dancer. A functional diagram of the footwear broken into its sensory components is found in Appendix B. The shoes have three pressure sensors (force-sensitive resistors) in the front, which “respon[d] to the dancer’s rocking of the foot side-to-side” and to “downward pressure during pointing” (Paradiso et al., 2000, p. 513). The heel has a strip of polyvinylidene flouride (PVDF) that responds to pressure more dynamically, and can detect weight distribution. Two resistive bend sensors (similar to those on the Lady’s Glove) lace the bottom of the insole. The shoes have a layer of copper on the bottom (labeled “Pickup Electrode” in the figure) that “capacitively coupl[es] to transmitting electrodes, placed on the stage, that broadcast a constant sinusoidal signal at 55 kHz” (Paradiso et al., 2000, p. 513). Capacitive coupling is the ability of a change in voltage of an electrode to induce a change in voltage of a separate electrode. The further the shoe from the transmitter, the fainter the signal, which is used to indicate the height of the foot.

The remaining position, motion, and orientation data of Expressive Footwear is gathered by a circuit board attached to the outside of the shoe. The board has a three-axis compass to measure orientation (yaw), and a two-axis tilt accelerometer to measure pitch (Paradiso and Hu, 1997, pp. 165-166). An additional three-axis accelerometer was added just to detect “shocks and kicks” of greater force, while a gyroscope is used to measure “spins and twists” (Paradiso et al., 2000, p. 515). The board has a sonar receiver that “detects 40 kHz [signals] sent from as many as four locations around the stage” (Paradiso et al., 2000, p. 515) and that can determine the horizontal position of the shoe. Finally, the board has a microprocessor (PIC16C711) that converts all the analog signals into digital signals and transports them over a 20Kbit per second radio frequency (RF) link to a receiver, from an antenna found on the back of the shoe. Each shoe transmits at its own frequency, and requires its own “base station” (Paradiso et al., 2000, p. 518).

Unlike SICIB, which uses the complicated algorithms of Escamol to generate music, Expressive Footwear uses the MIDI program Rogus to map its many sensory outputs directly onto the music’s characteristics. This technique allows the dancers to have immediate control over the sound, but it requires far more practice and experience

(Paradiso et al., 2000, p. 523). Expressive Footwear has had many public showings, and the mappings are unique every time. In general, the quick, hard motions measured by the shock accelerometers and pressure sensors are converted into percussive sounds, while the tilt and orientation sensors are used to adjust pitch or panning (Borden, 2001). Positions of the shoes often change the active instrument sounds, while height (when over the transmitting pad) often changes volume. In one application (used at the American Dance Festival of July, 1999), the computer splits up the stage into nine zones (Paradiso et al., 2000, p. 525). Some spaces trigger specific samples, while others trigger portions of a MIDI sequence that can be modified by tilting and bending the shoes. Like clicking a mouse on a computer, the dancers can “change programs by stamping” (Borden, 2001). These are just some examples of the possible uses of the Expressive Footwear, as the devices have applications that extend far beyond their musical possibilities.

### C. Body Obstruction

#### 1. Twin Towers

By monitoring specific areas of space, sensors can produce signals when the body is used to obstruct the transmission. It is often quite appealing to generate music in this fashion, as the musician does not need to hold or wear any sensory devices. This scenario is often ideal for public spaces and museum exhibits where the general public is invited to take part in the creation.

A smaller example of this kind of device is the Twin Towers (shown in Figure 3), developed by Tarabella and Bertini at the University of Pisa. The Towers use two sets of near-IR transmitters and receivers, one for each hand. Each sensory assembly has a “wide-angle transmitting diode (Tx) and [four] narrow-angle receiving (Rx) photo transistor[s]”

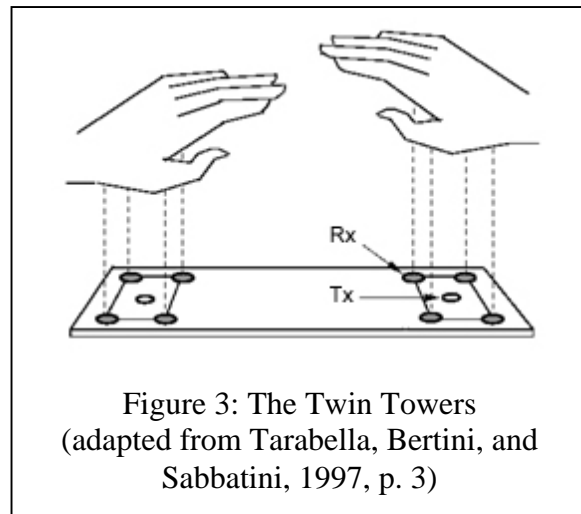
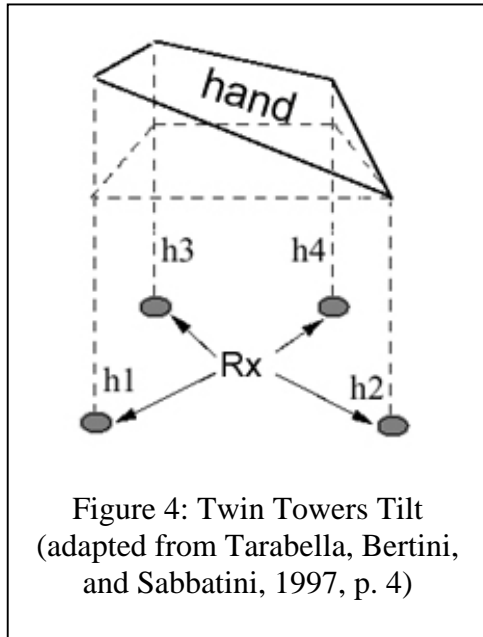

Figure 3: The Twin Towers  
(adapted from Tarabella, Bertini, and Sabbatini, 1997, p. 3)

surrounding it (Tarabella, Magrini, and Scapellato, 1997, p. 66). Each of the receivers

generates a signal based on the amount of reflected light: the greater the distance of the hands from the device, the less light is sensed by the receivers. The hands are used in different positions and orientations to alter the way the light is reflected. The sensors are connected to the computer through a serial line, at which point other information such as height, rotation, and velocity of the hands is calculated (Tarabella, Magrini, and Scapellato, 1997, p. 67). With this configuration of sensors, it is easy to determine the two-axis tilt of the hand by comparing the four receivers relative to each other, while approximating the palm of the hand as an 8cm by 8cm square. The hand is split into four regions, “each one seen by a separate Rx phototransistor” (Tarabella, Bertini, and Sabbatini, 1997, p. 4). If the hand is tilted slightly to one side (represented by the dark square shown in Figure 4), the heights measured from the four receivers (shown as



vertical dotted lines) can be used to calculate tilt as:

$$A_{\text{side}} = h_1 + h_3 - h_2 - h_4 \quad (2)$$

where  $A_{\text{side}}$  is the amount the hand is tilted to the right (in cm), and  $h_1$ ,  $h_2$ ,  $h_3$  and  $h_4$  are the four heights measured in cm from the receivers to the appropriate region of the hand (Tarabella, Bertini, and Sabbatini, 1997, p. 4). To find the tilt of the hand forward or backward, the calculation is similar:

$$A_{\text{front}} = h_1 + h_2 - h_3 - h_4 \quad (3)$$

where  $A_{\text{front}}$  is the amount the hand is tilted

forward in cm, and the other variables are defined as before. These calculations can also be used to provide the velocity of the hands by “computing time elapsed between two different positions” (Tarabella, Bertini, and Sabbatini, 1997, p. 5). The collected data is then assigned by the computer in real-time to aspects of the music, such as pitch and amplitude.

## 2. Magic Carpet

Another device that relies on the body obstructing a transmission is the Magic Carpet. Also a component of MIT's *Brain Opera*, the Magic Carpet permits "a general audience [to] interact with musical sound and structure at a variety of interactive stations" (Paradiso et al., 1997). For this type of system to function, it is essential that no electronics need to be worn. The device is comprised of a sensing mat that everyone can walk across, and two microwave sensors that detect hand and body motions. The sensing mat is a grid of sixteen by thirty-two piezoelectric wires, placed under a carpet, "used to sense foot pressure and position" (Paradiso et al., 1997). Each cable will "produce a voltage when pressed or flexed anywhere along its length" (Paradiso et al., 1997), and the amplitude of the voltage "is proportional to the intensity of the dynamic foot pressure" (Paradiso, 1999b, p. 144). Thus, the output of one set of wires will provide the X position, while the other set of wires will provide the Y position. Together they account for the entire two-dimensional space. The two motion sensors utilize the Doppler effect (when a wave is transmitted, and reflected off a moving surface, it will come back at a different frequency). Each sensor assembly of the Magic Carpet has a microwave antenna that continuously transmits a signal. If a moving hand obstructs it, the reflected signal is shifted, and when this signal is mixed with the original transmitted signal, it produces a difference in frequency. The velocity of the hand is then a function of this frequency, while the size and distance of the hand is a function of the resulting amplitude (Paradiso et al., 1997). By comparing the outputs of two of these types of sensors, information regarding "general amount of motion", velocity, and "direction of the motion", can easily be obtained (Paradiso, 1999b, p. 145).

The Magic Carpet has many modes of operation. In a typical scenario, the wires under the mat correspond to specific notes ("Note-On" events in MIDI), and the pressure with which they are pressed correspond to note velocity (Paradiso et al., 1997). Often, "footsteps trigger low, droning sounds, [while intensity is] dictated by foot pressure and pitch derived from step location" (Paradiso, 1999b, p. 145). A more visceral mapping utilizes natural sounds, as "wind and rain effects [are] driven by upper body motion

(thunder for very fast movements), and percussive, crashing and crunching sounds [are] triggered by steps” (Paradiso, 1999b, p. 145).

#### D. Body Transmission

##### 1. Electric Field Sensing

The human body has a naturally high conductivity, and it can be used to transmit electric fields when a person comes in contact with a transmitter electrode. Some electronic instruments take advantage of the fact that “signal strength induced at a receiver electrode tuned to the transmitter’s frequency will increase as the person’s body (or portions of it) get closer” (Paradiso, 1997, p. 26). Utilizing this phenomenon to detect position of the body is known as electric field sensing. A 50-100kHz signal is sent through a transmitting electrode plate. If nothing is present between the transmitter and the receiver, a small capacitance ( $C_o$ ) can still exist in the circuit. Typically, the device will be calibrated to this value. When a performer comes in contact with the plate, “capacitive coupling from the transmitter into the hand ( $C_t$ ), hand into the receiver ( $C_r$ ), and body into ground ( $C_g$ )” can occur, as shown in Figure 5 (Smith et al., 1998, p. 55).

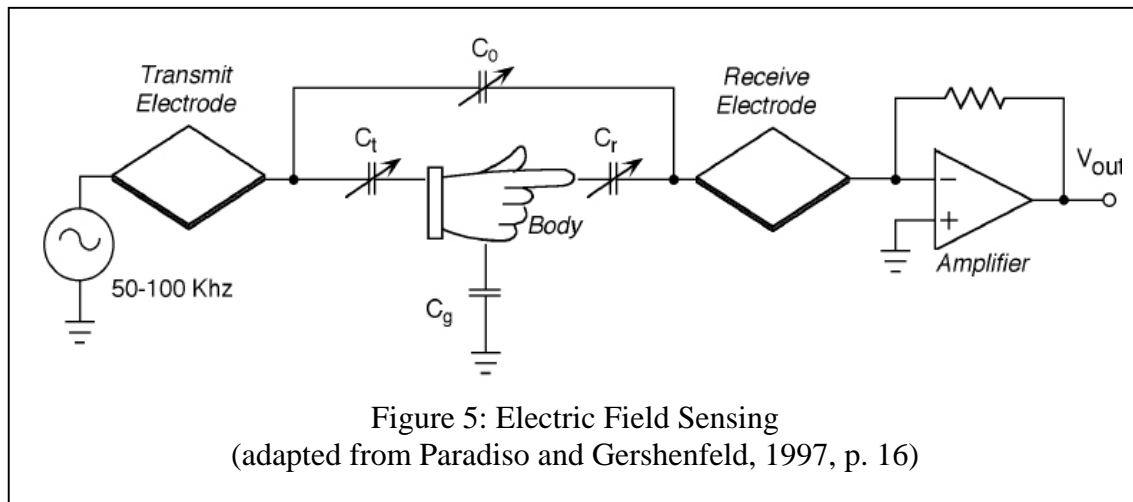

Figure 5: Electric Field Sensing  
(adapted from Paradiso and Gershenfeld, 1997, p. 16)

Since the human body has such a low internal resistance, it behaves like a perfect conductor, causing the value of  $C_g$  to be much greater in magnitude than the other capacitances. As the performer moves a hand closer to the receiver the effect of the  $C_g$  component increases, which reduces the current seen by the receiver. Amplifying  $C_g$  and measuring the resulting voltage ( $V_{out}$ ) gives a rough approximation to the distance of the

hand. Since the value of  $C_g$  varies depending on the size of the performer a number of calibration steps are needed before position can be accurately determined. (Paradiso and Gershenfeld, 1997, p. 16)

## 2. Sensor Chair

One instrument that uses electric field sensing, also from the *Brain Opera*, is the Sensor Chair. A block diagram of the chair, separated into its key components and functions, can be found in Appendix C. The chair has a copper transmitter electrode on its seat, which provides a large area for electrical coupling. The hands and feet then effectively become transmitters, and four receiving antennas in front of the chair, and two on the floor, detect the signal. The analog data from the six sensors is converted to digital signals and interpreted by a microprocessor. This device is also responsible for transmitting the pulse through the seat, reading in information from push-buttons near the feet, and sending data to a digital display (which is used to cue the performer) and halogen bulbs (which provide visual feedback for the audience).

The output information from the microprocessor uses MIDI to connect to other synthesizers and to the main computer. The sensors, seat plate, and other components of the Sensor Chair are shown in Figure 6. Similar to the configuration of the Twin Towers, the array of four sensors allows the computer to calculate hand position in two-dimensional space by relatively comparing the sensors. With this data

the computer can calculate velocity and the third dimension of space by analyzing the

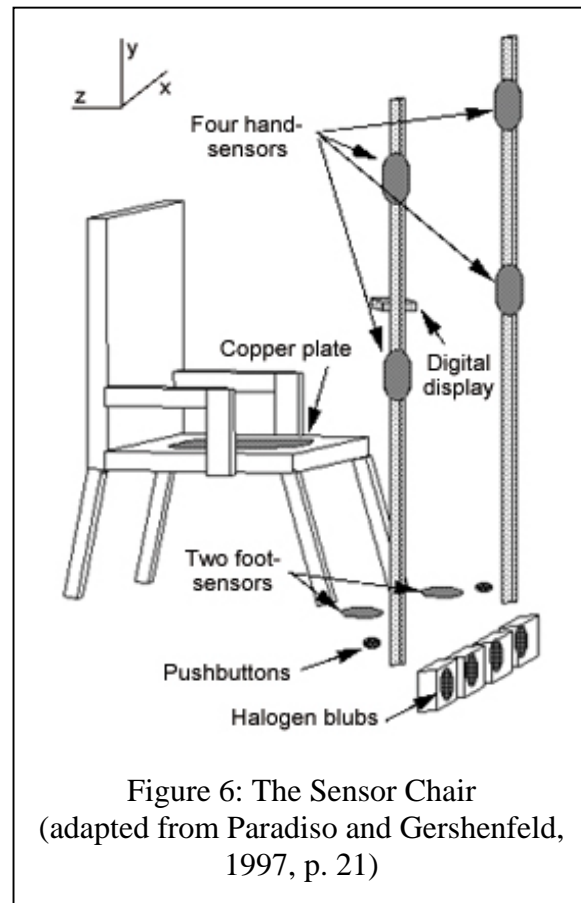

Figure 6: The Sensor Chair  
(adapted from Paradiso and Gershenfeld, 1997, p. 21)

intensity of the transmission over time. In a typical operating mode, the Sensor Chair uses the distance of the hands ( $z$ ) from the sensor plane to “launch a sound and adjust its volume, [while using] the position of the hand in the sensor plane ( $x,y$ ) to change the timbral characteristics” (Paradiso and Gershenfeld, 1997, p. 24). In “percussion mode”, the computer divides the  $x,y$  plane into separate “zones”, which contain “sounds and sequences triggered when the hand moves into their boundary” (Paradiso and Gershenfeld, 1997, p. 24). In addition, the feet sensors typically trigger percussive sounds and the pushbuttons are often used to change between modes or to issue “MIDI events independent of the sensor readings” (Paradiso, 1997, p. 26).

#### IV. CONCLUSION

Gesture-based electronic musical instruments can provide an almost unlimited range of artistic expression through their unique uses of light, motion, and pressure sensing. This level of expression is a direct result of the careful research and design used to construct them. While it is relatively simple to make a device that converts movement into sound, it takes careful design to develop a system that can rival, and hopefully exceed, the creative musical possibilities of traditional acoustic instruments. In addition, the appropriate association between gesture and sound is not always immediately obvious, and it requires a flexible protocol such as MIDI to be realized. As our understanding of technology improves, we open new doorways of creative expression, and discover new ways to portray ourselves through music.

## V. WORKS CITED

- Borden, D., 2001, Director of the Digital Music Program, Department of Music.  
Interview with author. Cornell University, October 26.
- Camurri, A., 1999, Music Content Processing and Multimedia: Case Studies and Emerging Applications of Intelligent Interactive Systems. *Journal of New Music Research*, Vol. 28, No. 4, pp. 351-363.
- Ferrazzin, D., Di Domizio, G., Salsedo, F., Avizzano, C., Tecchia, F., and Bergamasco, M., 1999, Hall Effect Sensor-Based Linear Transducer. In: *Proceedings of the 1999 IEEE International Workshop on Robot and Human Interaction*. Pisa, Italy.
- Flock of Birds: Six Degrees-of-freedom Measurement Device, 2000. Burlington, VT: Ascension Technology Corporation. <http://www.ascension-tech.com/products/flockofbirds/>. Accessed on: October 29, 2001.
- Goldstein, M., 1998, Gestural Coherence and Musical Interaction Design. In: *Proceedings of the 1998 IEEE International Conference on Systems, Man and Cybernetics*. Menlo Park, CA.
- Hass, J., 1998, Musical Instrument Digital Interface Overview. Indiana University, Bloomington, IN. <http://www.indiana.edu/~emusic/MIDI.html>. Accessed on: November 15, 2001.
- Marrin, T., 1996, Toward an Understanding of Musical Gesture: Mapping Expressive Intention with the Digital Baton. Unpublished Master's thesis, Massachusetts Institute of Technology, Cambridge, MA.  
<http://marrin.www.media.mit.edu/people/marrin/Thesis.htm>. Accessed on: October 30, 2001.



- Morales-Manzanares, R., Morales, E., Dannenberg, R., and Berger, J., 2001, SICIB: An Interactive Music Composition System Using Body Movements. *Computer Music Journal*, Vol. 25, No. 2, pp. 25-36.
- Paradiso, J., 1999a, American Innovations in Electronic Musical Instruments. *NewMusicBox*, Vol. 1, No. 6. [http://www.newmusicbox.org/third-person/index\\_oct99.html](http://www.newmusicbox.org/third-person/index_oct99.html). Accessed on: November 16, 2001.
- , 1999b, The Brain Opera technology: New Instruments and Gestural Sensors for Musical Interaction and Performance. *Journal of New Music Research*, Vol. 28, No. 2, pp. 130-149.
- , 1997, Electronic Music: New Ways to Play. *IEEE Spectrum*, Vol. 34, No. 12, pp. 18-30. <http://www.spectrum.ieee.org/select/1297/muse.html>. Accessed on: October 8, 2001.
- Paradiso, J., Abler, C., Hsiao, K., and Reynolds, M., 1997, The Magic Carpet: Physical Sensing for Immersive Environments. *Presented at the ACM 1997 SIGCHI Conference*. Atlanta, GA, March 25-27.
- Paradiso, J., and Gershenfeld, N., 1997, Musical Applications of Electric Field Sensing. *Computer Music Journal*, Vol. 21, No. 2, pp. 20-24.
- Paradiso, J., Hsiao, K., Benbasat, A., and Teegarden, Z., 2000, Design and Implementation of Expressive Footwear. *IBM Systems Journal*, Vol. 39, No. 3-4, pp. 511-529.
- Paradiso, J., and Hu, E., 1997, Expressive Footwear for Computer-Augmented Dance Performance. In: *First International Symposium on Wearable Computers*. Cambridge, MA: MIT Press.

- Paradiso, J., and Sparacino, F., 1997, Optical Tracking for Music and Dance Performance. In: *Fourth Conference on Optical 3D Measurement Techniques*. Zurich, Switzerland.
- Smith, J., White, T., Dodge, C., Paradiso, J., and Gershenfeld, N., 1998, Electric Field Sensing for Graphical Interfaces. *IEEE Computer Graphics and Applications*, Vol. 18, No. 3, pp. 54-60.
- Tarabella, L., Bertini, G., and Sabbatini, T., 1997, The Twin Towers: a Remote Sensing Device for Controlling Live-interactive Computer Music. In: *Proceedings of the 2nd International Workshop on Mechatronical Computer Systems for Perception and Action*. Pisa, Italy.
- Tarabella, L., Magrini, M., and Scapellato, G., 1997, Devices for Interactive Computer Music and Computer Graphics Performances. *IEEE First Workshop on Multimedia Signal Processing, 1997*, pp. 65-70.

## VI. APPENDICES

### Appendix A: Digital Baton – Block Diagram

(adapted from Paradiso, 1997, p. 25)

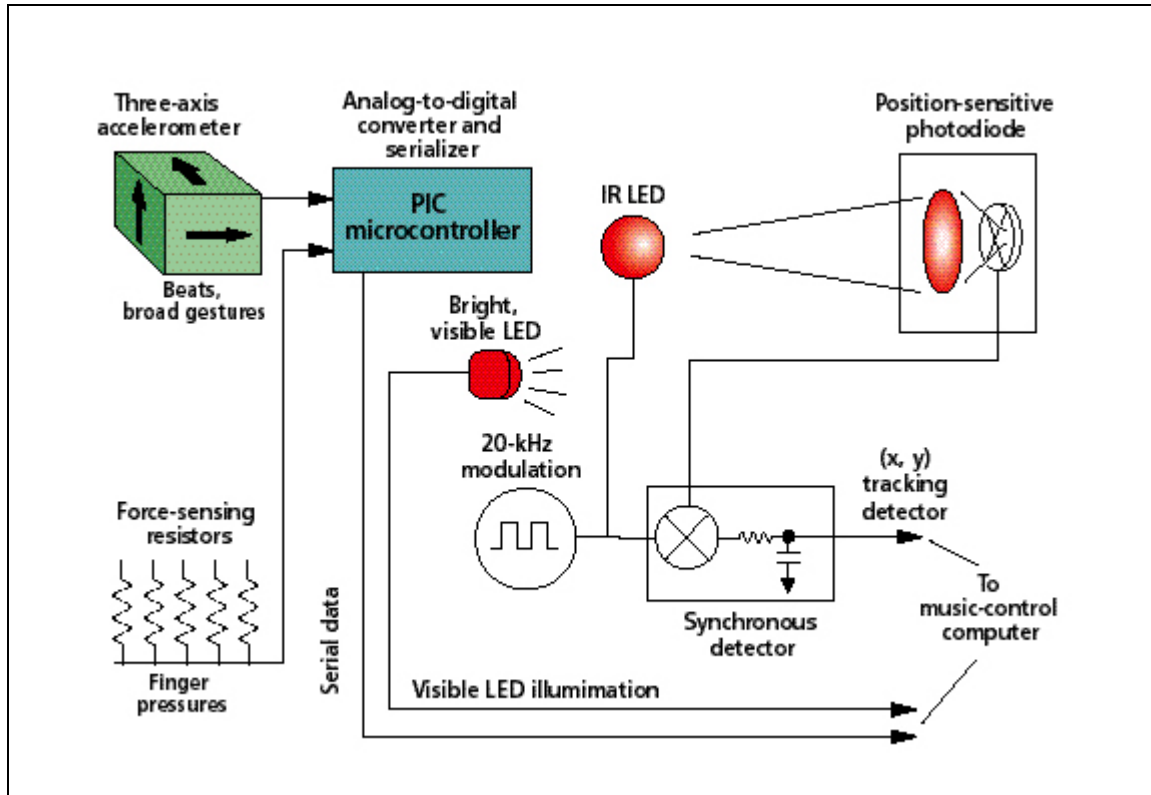

## Appendix B: Expressive Footwear – Functional Diagram

(adapted from Paradiso et al., 2000, p. 514)

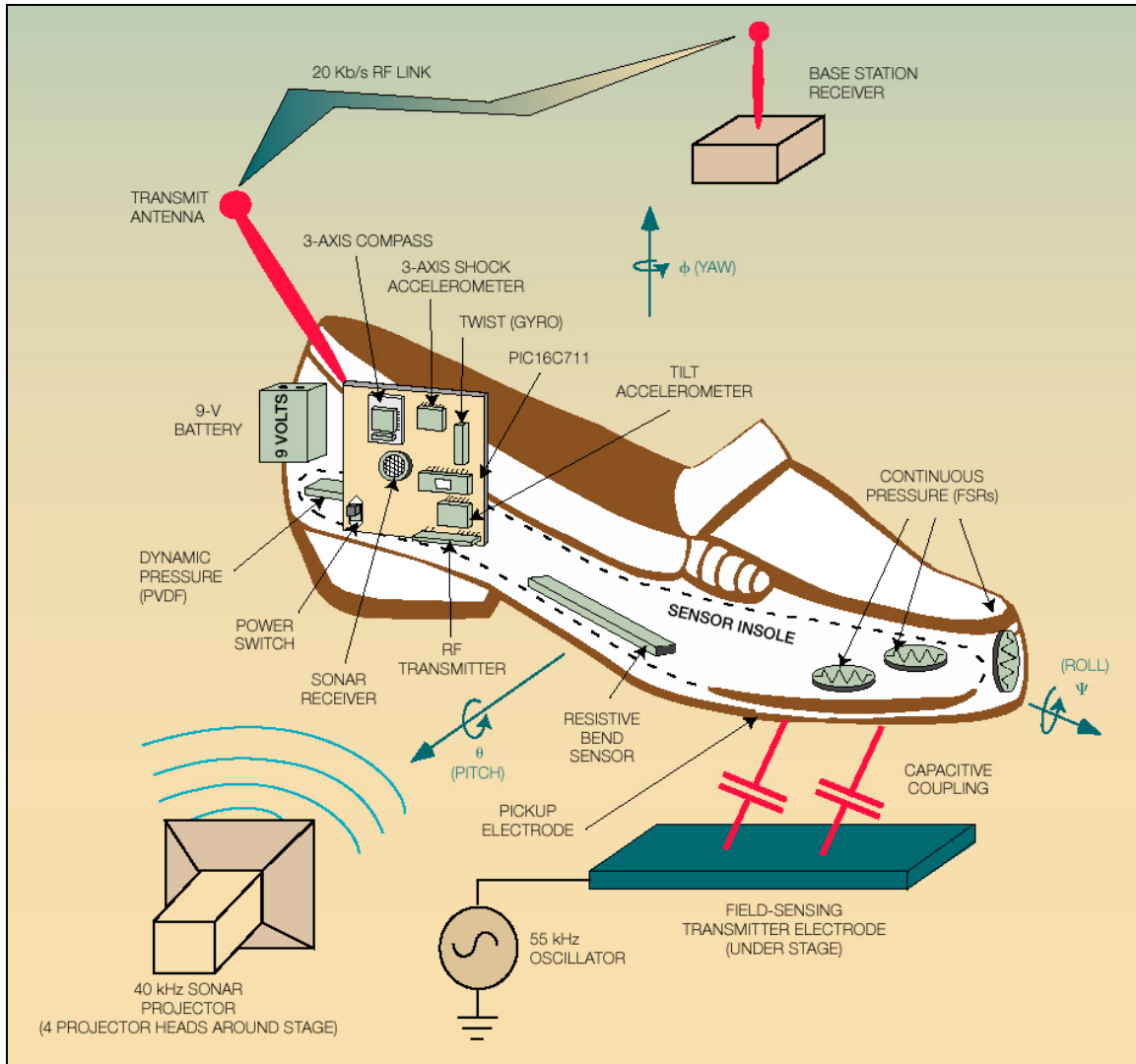

### Appendix C: Sensor Chair – Block Diagram

(adapted from Paradiso, 1997, p. 26)

